

Bending radii for cold forming of quenched and tempered special structural steels

ThyssenKrupp
high strength

N-A-XTRA®

and

ThyssenKrupp
high strength

XABO®

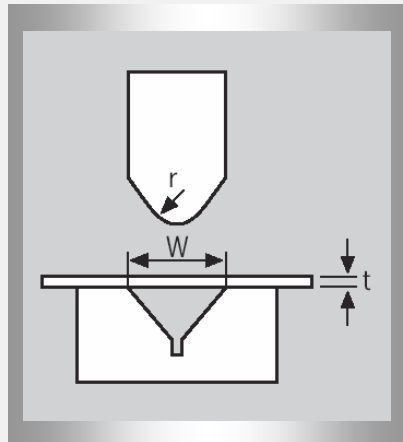

| Steel grade | Plate thickness t [mm] | | | |
|----------------------------|------------------------|-------|------------|-------|
| | t ≤ 6 | | t > 6 ≤ 16 | |
| | | ⊥ | | ⊥ |
| N-A-XTRA® 700 | 2,5 t | 2,0 t | 3,0 t | 2,0 t |
| N-A-XTRA® 800 | 3,0 t | 2,5 t | 3,5 t | 2,5 t |
| N-A-XTRA® 890 / 960 / 1100 | 3,5 t | 3,0 t | 4,0 t | 3,0 t |

|| = bending axis parallel to rolling direction

⊥ = bending axis perpendicular to rolling direction

For bend angles ≤ 90°

For more information see processing recommendation brochure

